

## RAILWAY RESISTORS MODEL EMS

### TECHNICAL DESIGN

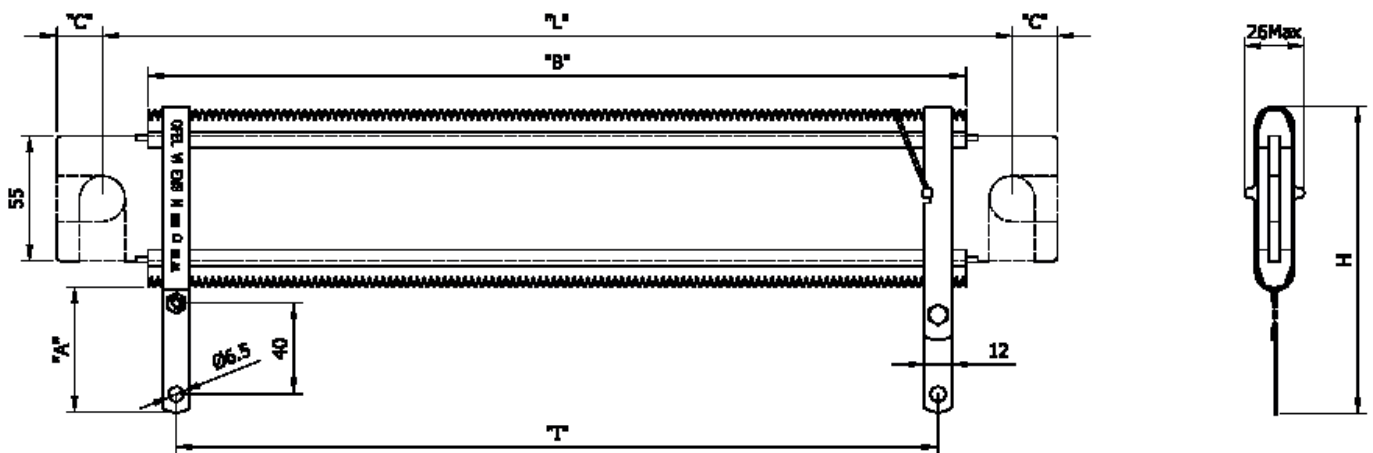

### GENERAL FEATURES

TYPE EMS	EMS 5	EMS 6	EMS 7	EMS 8	EMS 9	EMS 10
Power rating	850 W	1000 W	1200 W	1350 W	1500 W	1650 W
Resistance Min.	1R	1R	1R5	1R5	2R	2R
Resistance Max	100R	130R	160R	180R	200R	200R
Max Voltage	1000 V	1000 V	1000 V	1000 V	1000 V	1000 V
DIMENSIONS	EMS 5	EMS 6	EMS 7	EMS 8	EMS 9	EMS 10
L mm	340	400	460	520	580	650
B mm	300	360	420	480	540	610
C mm	20	20	20	20	20	20
A mm	55	55	55	55	55	55
I mm	275	335	395	455	515	585
H mm	140	140	140	140	140	140

THE OHMIC VALUE SHOWN ( MIN – MAX ) ARE INTENDED AS TOTAL RESISTANCE OF WINDING

## GENERAL FEATURES

These are high-tension resistors consisting of a stainless steel frame holding the insulating inserts in ceramic material, with the resistive wire windings.

Given their flat shape, they are suitable for assembly in groups with several elements.

These resistors are used in start up and adjustment of motors, in electric braking devices and in load systems for generating sets, testing benches, suppression of harmonics and grounding of the star centre.

The high value of power and the great amount of energy that can be dissipated are obtained by the important content of alloy in the winding and by the high impulse temperatures that can be supported without creating alterations or damages. The high level of insulation is obtained through the use of top quality ceramic materials.

## ELECTRICAL CHARACTERISTICS

- Standard tolerance:  $\pm 5\%$
- Temperature coefficient  $\leq 100$  ppm/ $^{\circ}\text{C}$
- Maximum tension applicable 1000 V
- Maximum utilisation temperature  $-55^{\circ}\text{C} / +500^{\circ}\text{C}$  ( $800^{\circ}\text{C}$  for impulses depending on the alloy used)

The nominal Pn power is considered for resistors placed with the long side horizontally and the shorter side vertically, free in circulating air, with an environmental temperature of  $25^{\circ}\text{C}$ .

With forced ventilation the nominal power dissipation capacity of the resistor increases as a function of the air speed.

## OPTIONAL

- Ohm values off standard compatibly with production
- Intermediate sockets
- Off standard tolerances